



Bharatiya Vidya Bhavan's

SARDAR PATEL COLLEGE OF ENGINEERING

(Government Aided Autonomous Institute)

Munshi Nagar, Andheri (W) Mumbai - 400058

**END SEMESTER November 2025 / RE - EXAM January 2026**

Program: Mechanical

S. Y. B. Tech (M) Sem B

Duration: 03 hours

Course Code: ES-BTM301

Maximum Points: 100

Course Name: Linear algebra & Vector calculus

Semester: III

Notes: 1) Attempt any 5 out of 7 questions

2) Use of non-programmable calculator is allowed.

21/11/20

Q.No.	Questions	Points	CO	BL	Mo No
1a)	Find a unit vector normal to the surface $xy^3z^2 = 4$ at point $(-1, -1, 2)$	06	4	1,2	3
1b)	Find the rank of $\begin{bmatrix} 2 & 3 & -1 & -1 \\ 1 & -1 & -2 & -4 \\ 3 & 1 & 3 & -2 \\ 6 & 3 & 0 & -7 \end{bmatrix}$	06	1	1,2,3	1
1c)	Find the Fourier Series of $f(x) = \begin{cases} -x & -\pi < x \leq 0 \\ x & 0 \leq x < \pi \end{cases}$	08	2	2,3	5
2a)	Solve $\begin{aligned} 2x - y + z + w &= 0 \\ x - y - w &= 0 \\ x + 2z + 2w &= 0 \end{aligned}$	06	1	1,3	1
2b)	Find the bilinear transformation which maps the point $z = 1, i, -1$ onto $w = i, 0, -i$	06	3	1,2,3	7
2c)	Obtain the half range sine series $f(x) = x(\pi - x) \quad 0 < x < \pi$ Hence show that $\sum_{n=1}^{\infty} \frac{1}{n^6} = \frac{\pi^6}{945}$	08	2	1,3	6

**END SEMESTER November 2025 / RE - EXAM January 2026**

3a)	Verify Divergence Theorem for $\vec{F} = 4x\hat{i} - 2y^2\hat{j} + z^2\hat{k}$ taken over the bounded by the cylinder $x^2 + y^2 = 4, z = 0, z = 3$	10	4	2,3	4
3b)	Verify Cayley-Hamilton's theorem for $A = \begin{bmatrix} 2 & -1 & 1 \\ -1 & 2 & -1 \\ 1 & -1 & 2 \end{bmatrix}$ & hence obtain A^{-1} .	10	1	2,3	2
4a)	Find the values and eigen vectors of the matrix. $A = \begin{bmatrix} 8 & -6 & 2 \\ -6 & 7 & -4 \\ 2 & -4 & 3 \end{bmatrix}$	10	1	1,2	2
4b)	Verify Stoke's theorem for the vector field $\vec{F} = (x^2 - y^2)\hat{i} + 2xy\hat{j}$ over the box bounded by planes $x = 0, x = a, y = b, z = C$ if the face $z = 0$ is cut.	10	4	1,2,3	4
5a)	In usual notations prove that $\text{Divgrad } r^n = n(n+1)r^{n-2}$	06	4	1,3	4
5b)	Obtain the Fourier Series for $f(x) = \frac{1}{4}(\pi - x)^2$ in $0 < x < 2\pi$	06	2	2,3	5
5c)	Show that the transformation $w = \frac{3-z}{z-2}$ transforms the circle with center $\left(\frac{5}{2}, 0\right)$ and radius $\frac{1}{2}$ in the z -plane into the imaginary axis in the w -plane	08	3	1,3	7
6a)	Define a unitary matrix. if $N = \begin{bmatrix} 0 & 1+2i \\ -1+2i & 0 \end{bmatrix}$ is a matrix, then show that $(I - N)(I + N)^{-1}$ is a unitary matrix, where I is an identity matrix.	06	1	2,3	1



Bharatiya Vidya Bhavan's SARDAR PATEL COLLEGE OF ENGINEERING

(Government Aided Autonomous Institute)
Munshi Nagar, Andheri (W) Mumbai - 400058



END SEMESTER November 2025 / RE - EXAM January 2026

6b)	Find the Fourier Series for function $f(x)$ defined by $f(x) = \begin{cases} \pi x & 0 \leq x \leq 1 \\ \pi(2-x) & 1 \leq x \leq 2 \end{cases}$	06	2	1,2,3	6
6c)	Prove that $\vec{F} = (y^2 \cos x + z^3)\hat{i} + (2y \sin x - 4)\hat{j} + (3xz^2 + 2)\hat{k}$ is conservative and find the scalar potential Φ .	08	4	2,3	3
7a)	For what values of 'a' and 'b' the equations $x + 2y + 3z = 4$ $x + 3y + 4z = 5$ $x + 3y + az = b$ Have i) No solution ii) A unique solution Infinite number of solutions	06	1	1,3	1
7b)	Apply Green's thm to evaluate $\oint_C (y - \sin x)dx + \cos x dy$ where C is the plane triangle enclosed by the lines $y = 0$, $x = \pi/2$ & $y = \frac{2x}{\pi}$.	06	4	2,3	4
7c)	Find an analytic function $w = u + iv$ given that $v = \frac{x}{x^2 + y^2} + \cosh x \cos y$	08	3	1,2,3	7

**END SEMSTER EXAM, NOVEMBER-2025 / RE-EXAMINATION, JANUARY-2026**

Program: B.Tech. Mechanical

Duration: 3 Hour

Course Code: PCC-BTM302

Maximum Points: 100

Course Name: Thermodynamics

Semester: III

Notes:

- 1) Solve: Any FIVE Questions.
- 2) Answers must be SPECIFIC and in legible handwriting.
- 3) Draw neat system diagram/s and process diagrams wherever necessary.
- 4) Use Steam tables and Mollier Chart provided by Examination section, if required.
- 5) Illustrate your answers with suitable examples as and where necessary.
- 6) Assume suitable data wherever necessary and state the same.

24/11/25

Q.	Question	Points	CO	BL	Module
1.	a) Justify: i) Energy of a thermodynamic system is a state function ii) Heat transfer in a thermodynamic process is a path function. Draw: Neat process diagrams.	10	1	III, VI	1 2
	b) A stationary fluid system undergoes a thermodynamic cycle as below: 1) Process 1-2: Isochoric heat addition of 235 kJ/kg, 2) Process 2-3: Adiabatic expansion to its original pressure with loss of 70 kJ/kg of internal energy and 3) Process 3-1: Isobaric compression to its original volume with a heat rejection of 200 kJ/kg. Evaluate: Work transfer, heat transfer and change in internal energy for each process. Draw: Neat process diagram.	10	1, 4	II, III, VI	1, 2
2.	a) Using general form of steady flow energy equation, Derive: Steady flow energy equation for i) Turbine and ii) Nozzle. State: Assumptions made in each case. Draw: neat schematic diagram for each case.	08	3	I, III, IV	2
	b) Steam expands isentropically in a nozzle from at 10 bar, 250°C to 0.1 bar. Expansion of steam through the nozzle is reversible and adiabatic with a mass flow rate of 1 kg/s. Neglecting the velocity of steam at the inlet, Evaluate: i) Velocity of steam at nozzle exit and ii) exit area of the nozzle. Draw: Neat i) System diagram, ii) T-s and ii) h-s diagram.	12	4	III, VI	2, 5



Bharatiya Vidya Bhavan's
SARDAR PATEL COLLEGE OF ENGINEERING

(Government Aided Autonomous Institute)
Munshi Nagar, Andheri (W) Mumbai – 400058



END SEMSTER EXAM, NOVEMBER-2025 / RE-EXAMINATION, JANUARY-2026

3.	a) Explain: Kelvin-Planck statement and Clausius statement of second law of thermodynamics. Draw: Neat block diagrams for each statement and justification of equivalence of both the statements.	06	1	II, III	3
	b) Draw: Neat block diagrams and Explain: Principle of working of a Refrigerator and Heat Pump. Prove: $CoP_{HP} = CoP_R + 1$.	06	1, 3	II, III, VI	3
	b) 1 kg of ice at $-5^\circ C$ is exposed to atmosphere which is at $20^\circ C$. The ice melts and comes in thermal equilibrium with the atmosphere. Evaluate: Total change in the entropy of the system during the entire process. Take c_p of ice = 2.093 kJ/kg.K and latent heat of fusion of ice, $h_{sf} = 333.3 \text{ kJ/kg}$. Draw: Neat T-s diagram. <i>* Assume $C_{p,water} = 4.1867 \text{ kJ/kg.K}$</i>	08	4	III, VI	4
4.	a) Explain: Working of an ideal Rankine cycle for a steam power plant. Draw: Neat i) system diagram and ii) p-V and T-s diagrams of the cycle.	08	1, 3	II, III	5
	b) Explain: i) Steam rate and ii) Heat rate of a steam power plant. In a steam power plant working on an ideal Rankine, steam at 20 bar, $350^\circ C$ is expanded in a steam turbine to 0.08 ^{0.1} bar. Evaluate: Thermal efficiency of the plant. Draw: Neat h-s diagram for the cycle.	12	4	II, VI	5
5.	a) Explain: Working of a closed cycle gas turbine plant, operating on air standard Brayton cycle. Draw: Neat i) System diagram, ii) p-V and T-s diagram.	08	1	II, III	6
	b) In an air standard Otto cycle, the compression ratio is 8 and compression begins at $27^\circ C$ and 0.1 MPa. The heat added in the cycle is 1840 kJ/kg . Evaluate: i) Temperature and pressure at the cardinal points of the cycle, ii) Cycle efficiency. Draw: Neat p-V and T-s diagrams of the cycle. <i>* For Air, take $C_v = 0.718 \text{ kJ/kg.K}$ $\gamma = 1.4$</i>	12	4	I, I, IV	6
6.	a) Explain: Working of a Vapor Compression Refrigeration (VCR) cycle. Draw: Neat i) system diagram, ii) T-s diagram for the cycle.	08	1	II, III	3, 7
	b) Explain: Any one method of waste heat recovery for an open cycle gas turbine plant. Draw: Neat system diagram.	06	1	III, III	6, 7
	c) Explain: Working principle of fuel cells. Draw: Neat schematic diagram.	06	1	II, III	7
7.	Explain: ANY THREE of the following. Draw: Neat system diagram/ sketches/ process diagrams as applicable.	20	1	II, III	
	a) Dual cycle				6
	b) Thermodynamic equilibrium and its types				1



Bharatiya Vidya Bhavan's
SARDAR PATEL COLLEGE OF ENGINEERING

(Government Aided Autonomous Institute)
Munshi Nagar, Andheri (W) Mumbai - 400058



END SEMSTER EXAM, NOVEMBER-2025 / RE-EXAMINATION, JANUARY-2026

e) Concept of Trigeration				7
d) Joule's Experiment				2
e) Zeroth law of thermodynamics and IPTS				2



Bharatiya Vidya Bhavan's
SARDAR PATEL COLLEGE OF ENGINEERING

(Government Aided Autonomous Institute)
Munshi Nagar, Andheri (W) Mumbai – 400058



~~END SEMESTER EXAM, NOVEMBER 2025~~ / RE-EXAMINATION, JANUARY-2026

Program: B.Tech. Mechanical

Duration: 3 Hour

Course Code: PCC-BTM302

Maximum Points: 100

Course Name: Thermodynamics

Semester: III

7/1/26

Notes:

- 1) Solve: Any FIVE Questions.
- 2) Answers must be SPECIFIC and in legible handwriting.
- 3) Draw neat system diagram/s and process diagrams wherever necessary.
- 4) Use Steam tables and Mollier Chart provided by Examination section, if required.
- 5) Illustrate your answers with suitable examples as and where necessary.
- 6) Assume suitable data wherever necessary and state the same.

Q.	Question	Points	CO	BL	Module
1.	a) Explain: i) Quasi-static process ii) Thermodynamic work. Draw: neat system diagrams.	10	1	II, III	1
	b) A stationary fluid system undergoes a thermodynamic cycle as below: 1) Process 1-2: Isochoric heat addition of 235 kJ/kg, 2) Process 2-3: Adiabatic expansion to its original pressure with loss of 70 kJ/kg of internal energy and 3) Process 3-1: Isobaric compression to its original volume with a heat rejection of 200 kJ/kg. Evaluate: Work transfer, heat transfer and change in internal energy for each process. Draw: Neat process diagram.	10	1, 4	II, III, VI	1, 2
2.	a) Using general form of steady flow energy equation, Derive: Steady flow energy equation for i) Turbine and ii) Nozzle. State: Assumptions made in each case. Draw: neat schematic diagram for each case.	08	3	I, III, IV	2
	b) Steam at 15 bar, 300°C and 80 m/s enters a small turbine with a mass flow rate of 5000 kg/h and leaves the turbine at 0.1 bar, 40 m/s with 4% moisture. Expansion through the turbine is reversible and adiabatic. Evaluate: i) Shaft power developed by the turbine and ii) Diameters of inlet and discharge pipe of the turbine. Draw: Neat i) System diagram, ii) T-s and ii) h-s diagram.	12	4	III, VI	2, 5



Bharatiya Vidya Bhavan's
SARDAR PATEL COLLEGE OF ENGINEERING

(Government Aided Autonomous Institute)
Munshi Nagar, Andheri (W) Mumbai – 400058



~~END SEMESTER EXAM, NOVEMBER 2025~~ / RE-EXAMINATION, JANUARY-2026

3.	a) Explain: Kelvin-Planck statement and Clausius statement of second law of thermodynamics. Draw: Neat block diagrams for each statement and justification of equivalence of both the statements.	06	1	II, III	3
	b) Draw: Neat block diagrams and Explain: Principle of working of a Refrigerator and Heat Pump. Prove: $CoP_{HP} = CoP_R + 1$.	06	1, 3	II, III, VI	3
	b) 1 kg of ice at $-5^{\circ}C$ is exposed to atmosphere which is at $20^{\circ}C$. The ice melts and comes in thermal equilibrium with the atmosphere. Evaluate: Total change in the entropy of the system during the entire process. Take c_p of ice = 2.093 kJ/kg.K and latent heat of fusion of ice, $h_{sf} = 333.3 \text{ kJ/kg}$. Draw: Neat T-s diagram.	08	4	III, VI	4
4.	a) Draw: Neat i) system diagram and ii) T-s diagram for an ideal reheat cycle for a steam power plant. Explain: i) advantages of reheating and ii) necessary conditions for reheating the steam.	08	1, 3	II, III	5
	b) In a steam power plant working on an ideal Rankine, steam at 20 bar, $360^{\circ}C$ is expanded in a steam turbine to 0.08 bar. Evaluate: Thermal efficiency of the plant. Draw: Neat i) System diagram ii) T-s and h-s diagram for the cycle.	12	4	II, VI	5
5.	a) Explain: Working of a closed cycle gas turbine plant, operating on air standard Brayton cycle. Draw: Neat i) System diagram, ii) p-V and T-s diagram.	08	1	II, III	6
	b) In an air standard Otto cycle, the compression ratio is 8 and compression begins at $35^{\circ}C$ and 0.1 MPa. The heat added in the cycle is 2100 kJ/kg . Evaluate: i) Temperature and pressure at the cardinal points of the cycle, and ii) Cycle efficiency. Draw: Neat p-V and T-s diagrams of the cycle.	12	4	I, I, IV	6
6.	a) Explain: Working of a Vapor Compression Refrigeration (VCR) cycle. Draw: Neat i) system diagram, ii) T-s diagram for the cycle.	08	1	II, III	3, 7
	b) Explain: Any one method of waste heat recovery for an open cycle gas turbine plant. Draw: Neat system diagram.	06	1	III, III	6, 7
	c) Explain: Concept of Trigenation. Illustrate: with example of a working system/ prototype of cogeneration/ trigenation.	06	1, 3	II, III	7
7.	Explain: ANY THREE of the following. Draw: Neat system diagram/ sketches/ process diagrams as applicable	20	1	II, III	
	a) Diesel cycle				6



Bharatiya Vidya Bhavan's
SARDAR PATEL COLLEGE OF ENGINEERING

(Government Aided Autonomous Institute)
Munshi Nagar, Andheri (W) Mumbai - 400058



~~END SEMSTER EXAM, NOVEMBER-2025~~ / RE-EXAMINATION, JANUARY-2026

b) Thermodynamic systems and its types				1
c) Fuel cells				7
d) Joule's Experiment				2
e) Zeroth law of thermodynamics and IPTS				2



Bharatiya Vidya Bhavan's

SARDAR PATEL COLLEGE OF ENGINEERING

(Government Aided Autonomous Institute) Munshi Nagar,
Andheri (W) Mumbai - 4



END SEMESTER November 2025 / ~~RE-EXAM~~ January 2026

Program: Mechanical Engineering

Duration: 03 Hours.

Course Code: PC-BTM303

Maximum Points: 100

Course Name: Material and Manufacturing Science

Semester: III

Notes:

1. Question no 1 is compulsory
2. Attempt any four questions from the remaining six questions.
3. If necessary assume suitable data with justification
4. Draw neatly labeled sketches wherever required.

Q. No.	Questions	Points	CO	BL	Module No.
1A	Draw the Fe-C equilibrium diagram and accurately label the composition, phases, and critical transformation temperatures. On the same diagram, indicate the approximate positions of hypo-peritectic steel and hyper-peritectic steel based on their carbon contents relative to the peritectic composition. Apply the lever rule to examine how the liquid phase and δ -ferrite combine to form austenite during the reaction. Analyze this transformation by identifying the peritectic temperature and calculating the relative proportions of δ -ferrite and liquid present along the peritectic isotherm.	10	3	4,5	1
1B	A cylindrical workpiece is subjected to a cold upset forging operation. The starting piece is 80 mm in height and 55 mm in diameter. It is reduced in operation to a height of 45 mm. The work material has a flow curve defined by K 350 MPa and n 0.17. Assume a coefficient of friction of 0.1. Determine the force as the process begins, at intermediate heights of 70 mm, 55 mm, and at the final height of 45 mm. assume strain at initial 0.002.	10	1,2	3	7
2A	List the major mechanical methods used for producing metal powders. Describe the principle of powder formation in centrifugal atomization, Additionally, justify why plasma spheroidization is required after centrifugal atomization.	06	4	2	5
2B	In an orthogonal cutting test on a steel workpiece, the following data is recorded: Rake angle = 5° , Chip thickness ratio = 0.40, Width of cut = 3 mm, Uncut chip thickness = 0.6 mm, Material shear strength = 300 N/mm ² , Coefficient of friction between chip and tool = 0.75 Using Merchant's force diagram:	8	1,3	4,5	6



Bharatiya Vidya Bhavan's
SARDAR PATEL COLLEGE OF ENGINEERING

(Government Aided Autonomous Institute) Munshi Nagar,
 Andheri (W) Mumbai - 4

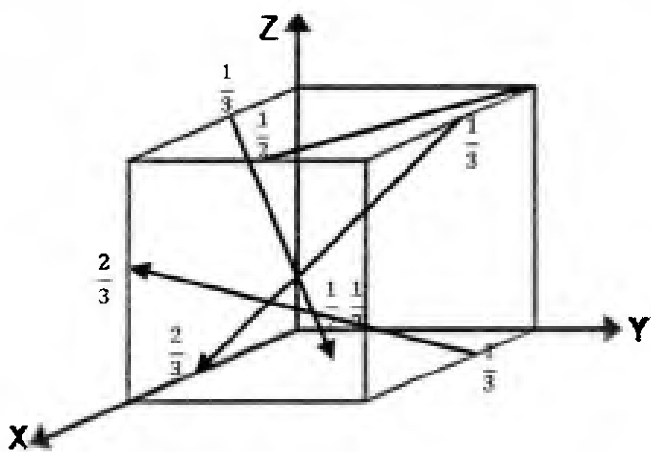
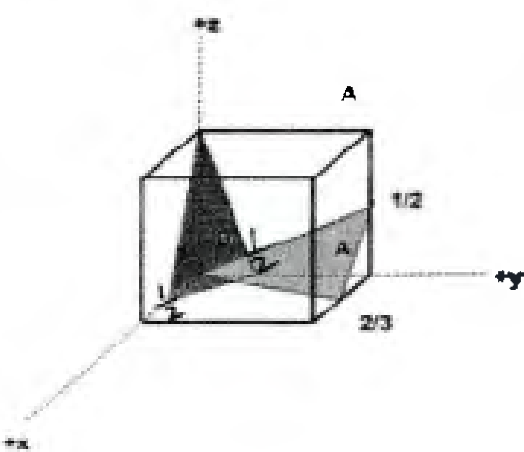

END SEMESTER November 2025 / RE-EXAM January 2026

	<ol style="list-style-type: none"> 1. Calculate the shear angle, shear force, and normal force on shear plane. 2. Determine the friction force and normal reaction at the tool chip interface. 3. Compute the cutting force and thrust force acting on the tool 				
2C	Derive an equation for the critical radius of a solid ball essential for solidification growth, supported by a labeled diagram. Analyze the role of Gibbs free energy in the phase transformation from liquid to solid, and explain its significance during the nucleation process.	06	3	4	1
3 A	<p>Determine the Miller indices for the directions and the planes shown in the following unit cell:[Note: provide the stepwise calculations for the given problem]</p>  	10(6+4)	3	5	1
3B	Examine the alloying principle behind stainless steels and classify them according to their phase structure and typical compositions. Using your understanding, determine which category of stainless steel can be hardened by heat treatment and critically analyze the	05	1	4	3



Bharatiya Vidya Bhavan's

SARDAR PATEL COLLEGE OF ENGINEERING

(Government Aided Autonomous Institute) Munshi Nagar,
Andheri (W) Mumbai - 4



END SEMESTER November 2025 / RE-EXAM January 2026

	metallurgical mechanisms that allow this transformation, contrasting it with the categories that cannot be heat-treated.				
3C	Identify and describe the most suitable heat treatment process to remove the residual stresses and enhance the ductility of the material. In your answer, analyze how this process affects the microstructure and mechanical properties of 0.45% carbon steel, and evaluate its effectiveness in restoring the desired properties. Additionally, draw a labeled diagram illustrating the heat treatment process and its impact on the steel's microstructure.	05	4,3	4	2
4A	<p>Discuss each case of the heat treatment process of Fe-0.65% C eutectoid steel rapidly cooled from a preheated temperature of 860°C (>727°C) as follows [NOTE: Analyze the resulting microstructures, evaluate the properties of the final product, and justify the suitability of each process.]</p> <ol style="list-style-type: none"> 1. rapidly cool to 650°C, hold for 30 seconds, rapidly cool to 400°C hold for 10⁴ s and quench to room temperature. 2. Rapidly cool to 350°C, hold for 10⁴ seconds, then quench to room temperature. 3. Rapidly cool to 270 °C, hold for 8s, rapidly cool to 100 °C, quench to room temperature; 	10	4	4	2

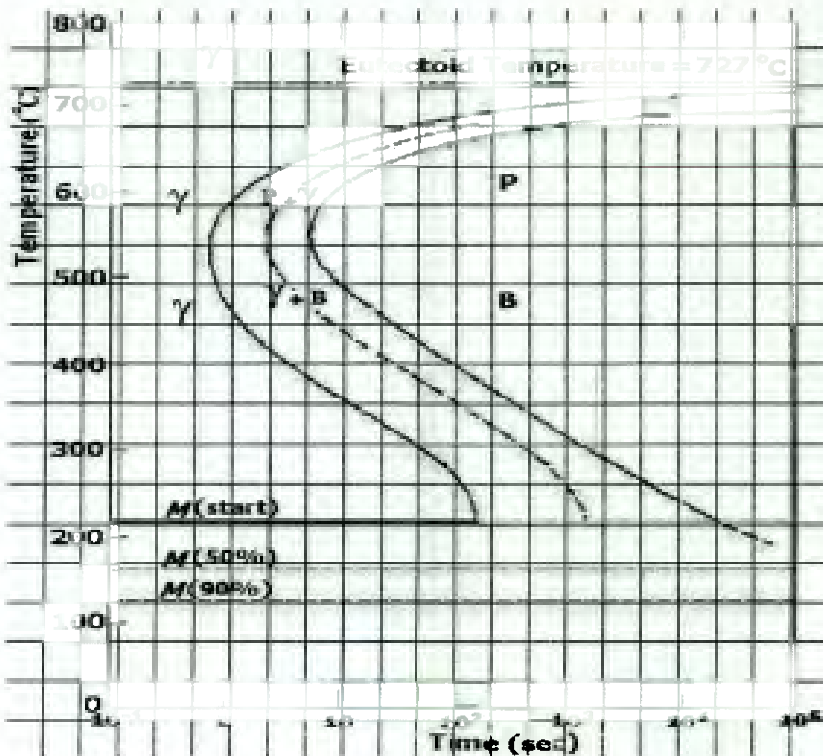



Bharatiya Vidya Bhavan's
SARDAR PATEL COLLEGE OF ENGINEERING

(Government Aided Autonomous Institute) Munshi Nagar,
Andheri (W) Mumbai - 4



END SEMESTER November 2025 / RE-EXAM January 2026

4B	<p>The Taylorian tool-life equation for machining C-40 steel with an H.S.S. cutting tool at a feed of 0.2 mm/min and a depth of cut of 2 mm is given by $VT^n = C$, where n and C are constants. The following V and T observations have been noted:</p> <table border="1"><tbody><tr><td>V (m/min)</td><td>30</td><td>35</td></tr><tr><td>T (min)</td><td>90</td><td>25</td></tr></tbody></table> <p>(i) Calculate n and C. (ii) Hence recommend the cutting speed for a desired tool life of 60 minutes.</p>	V (m/min)	30	35	T (min)	90	25	05	4	3	6
V (m/min)	30	35									
T (min)	90	25									
4C	<p>Using a schematic diagram, demonstrate the working of the powder bed fusion method in additive manufacturing, focusing on the laser-based system and the recoating mechanism.</p>	05	2	3	5						
5A	<p>Different alloy steel compositions are provided below. Analyze the given compositions, and based on the presence of the alloying elements, write the expected properties of each alloy steel.</p> <ol style="list-style-type: none">1. C: 0.06%, Cr: 18%, Ni: 8%, Mn: 1.0%2. C: 0.25%, Cr: 12.50%, V: 0.3%, Mo: 0.2%3. C: 1.95%, Mn: 0.8%, Ni: 1.5%, Co: 0.5%	06	4	4	0						
5B	<p>Define nanomaterials and elaborate on the top-down and bottom-up approaches used in their synthesis. Write any two applications of nanomaterials.</p>	06	4	4	4						
5C	<p>Apply your understanding of case hardening to explain its purpose and process. Analyze the following case hardening techniques by describing the elements added, their characterization, and applications:</p> <ol style="list-style-type: none">1. flame hardening2. carbonitriding3. Boronizing	08	3,4	4,5	2						
6A	<p>Wind turbine blades and automotive structural components experience continuous cyclic loading and require high stiffness and fatigue resistance. Explain why laminated composites with continuous fibers perform better than short-fiber or particulate composites in such applications. In your answer, describe the load transfer between matrix and fibers, the effect of fiber orientation on anisotropy, and recommend a suitable reinforcement type and matrix material with justification.</p>	08	4	4	4						
6B	<p>Apply your knowledge of material compositions to write the chemical composition of the following materials. Analyse their properties and suggest suitable engineering applications for each:</p> <ol style="list-style-type: none">1. Cartridge Brass2. Admiralty Gun Metal	06	3,4	3	3						



Bharatiya Vidya Bhavan's

SARDAR PATEL COLLEGE OF ENGINEERING

(Government Aided Autonomous Institute) Munshi Nagar,
Andheri (W) Mumbai - 4



END SEMESTER November 2025 / RE - EXAM January 2026

	3. Dow Metal.				
6C	Explain the extrusion and wire drawing processes, and discuss the advantages of hot working.	06	4	3	7
7A	Mild steel is being machined at a cutting speed of 220 m/min with a tool rake angle of 12° . The width of cut and uncut chip thickness are 2 mm and 0.2mm, respectively. If the average value of coefficient of friction between the tool and chip is 0.5 and the shear stress of the work material is 450N/mm ² . Determine: cutting and thrust components of machining force. Assume $2\Phi + \lambda - \alpha = (\pi/2)$.	06	2,3	4	6
7B	Identify the different types of powder density used in additive manufacturing and explain how each is measured. Discuss how this density values affect powder packing and melting behavior in Selective Laser Melting (SLM). Further analysis how layer thickness, laser power, scanning speed, and powder characteristics influence defect formation and the overall quality of the final AM product.	07	1,4	3	5
7C	A 325 mm-wide strip 36 mm thick is fed through a rolling mill with two powered rolls each of radius 250 mm. The work thickness is to be reduced to 33 mm in one pass at a roll speed of 50 rev/min. The work material has a flow curve defined by K 290 MPa and n 0.17, and the coefficient of friction between the rolls and the work is assumed to be 0.13. Determine if the friction is sufficient to permit the rolling operation to be accomplished. If so, calculate the roll force, torque, and horsepower.	07	2	3	7



Bharatiya Vidya Bhavan's
SARDAR PATEL COLLEGE OF ENGINEERING

(Government Aided Autonomous Institute) Munshi Nagar,
Andheri (W) Mumbai - 4



~~END SEMESTER November 2025~~ / RE - EXAM January 2026

Program: Mechanical Engineering

Duration: 03 Hours.

Course Code: PC-BTM303

Maximum Points: 100

Course Name: Material and Manufacturing Science

Semester: III

S. V. S. P. U. G. (M) Sem III

9/1/26

Notes:

1. Question no 1 is compulsory
2. Attempt any **four** questions from the remaining six questions.
3. If necessary **assume suitable** data with justification
4. Draw **neatly labeled sketches** wherever required.

Q. No.	Questions	Points	CO	BL	Module No.
1A	Draw the Fe-C equilibrium diagram and clearly label all phases, critical compositions, and transformation temperatures. On the same diagram, mark the positions of hypoeutectoid steel, eutectoid steel, and hypereutectoid steel with their respective carbon percentages. Apply the lever rule to determine how the liquid phase decomposes simultaneously into two solid phases during the eutectic transformation. Analyze this transformation by identifying the eutectic temperature and calculating the relative quantities of the solid phases formed along the eutectic isotherm.	10	3	4,5	1
1B	A cylindrical workpiece is subjected to a cold upset forging operation. The starting piece is 85 mm in height and 55 mm in diameter. It is reduced in operation to a height of 46 mm. The work material has a flow curve defined by $K = 350 \text{ MPa}$ and $n = 0.17$. Assume a coefficient of friction of 0.1. Determine the force as the process begins, at intermediate heights of 72 mm, 59 mm, and at the final height of 46 mm. assume strain at initial 0.002.	10	1,2	3	7
2A	Classify the mechanical methods of powder production. Explain the principle of powder formation in water atomization, describing the physics of droplet disintegration and solidification. Additionally, discuss why plasma spheroidization is required after producing powders through water atomization.	06	4	2	5
2B	During an orthogonal turning operation, the following data is obtained: Rake angle of tool = 10° , Cutting ratio = 0.45, Width of cut = 2.5 mm, Uncut chip thickness = 0.4 mm, Shear yield stress of work material = 240 N/mm^2 , Coefficient of friction at tool-chip interface = 0.6 Using Merchant's circle relations: 1. Determine the shear angle and shear force.	08	1,3	4,5	6



Bharatiya Vidya Bhavan's
SARDAR PATEL COLLEGE OF ENGINEERING

(Government Aided Autonomous Institute) Munshi Nagar,
Andheri (W) Mumbai - 4



~~END SEMESTER November 2025~~ / RE - EXAM January 2026

	<p>2. Calculate the normal force on the shear plane. 3. Determine the tangential force and normal force acting on the tool face.</p>				
2C	<p>Explain the concept of phase transformation and discuss the thermodynamic driving force associated with it. Derive an expression to estimate the change in Gibbs free energy (ΔG) under freezing conditions.</p>	06	3	4	1
3 A	<p>Determine the Miller indices for the directions and the planes shown in the following unit cell: [Note: provide the stepwise calculations for the given problem]</p>	10(6 +4)	3	5	1



Bharatiya Vidya Bhavan's
SARDAR PATEL COLLEGE OF ENGINEERING

(Government Aided Autonomous Institute) Munshi Nagar,
Andheri (W) Mumbai - 4



~~END SEMESTER November 2025~~ / RE - EXAM January 2026

3B	<p>Critically analyze the concept of stainless steel and classify the different types based on composition and microstructure. Apply your understanding to identify which category of stainless steel is not heat-treatable for hardening, and analyze the metallurgical reasons that prevent this type from responding to heat treatment.</p>	05	1	4	3
3C	<p>Identify and describe the most suitable heat treatment process to remove the residual stresses and enhance the ductility of the material. In your answer, analyze how this process affects the microstructure and mechanical properties of 0.45% carbon steel, and evaluate its effectiveness in restoring the desired properties. Additionally, draw a labeled diagram illustrating the heat treatment process and its impact on the steel's microstructure.</p>	05	4,3	4	2
4A	<p>Discuss each case of the heat treatment process of Fe-0.65% C eutectoid steel rapidly cooled from a preheated temperature of 860°C (>727°C) as follows [NOTE: Analyze the resulting microstructures, evaluate the properties of the final product, and justify the suitability of each process.]</p> <ol style="list-style-type: none"> 1. Rapidly cool it to 650°C. Hold for 60 seconds, then quench to room temperature. 2. Rapidly cool it to 450°C. Hold for 25 seconds, then quench to room temperature. 3. quench rapidly to 250°C. hold for 130 seconds before final water quench to room temperature. <div style="text-align: center; margin-top: 10px;"> <p>The diagram is a Temperature-Time (T-TTT) plot for Fe-0.65% C steel. The y-axis is Temperature in °C, ranging from 100 to 800. The x-axis is Time in seconds, on a logarithmic scale from 10⁰ to 10⁴. A horizontal line at 727°C is labeled 'Eutectoid Temperature = 727°C'. The diagram shows regions for Austenite (γ), Pearlite (P), Ferrite (F), and Martensite (M). Cooling curves are shown for different processes: 1. Cooling to 650°C, holding for 60s, then quenching. 2. Cooling to 450°C, holding for 25s, then quenching. 3. Quenching to 250°C, holding for 130s, then quenching. The diagram also indicates the Ms and Mf temperatures for martensite formation.</p> </div>	10	4	4	2



Bharatiya Vidya Bhavan's
SARDAR PATEL COLLEGE OF ENGINEERING

(Government Aided Autonomous Institute) Munshi Nagar,
Andheri (W) Mumbai - 4



~~END SEMESTER November 2025~~ / RE - EXAM January 2026

4B	The Taylorian tool-life equation for machining C-40 steel with an H.S.S. cutting tool at a feed of 0.2 mm/min and a depth of cut of 2 mm is given by $VT^n = C$, where n and C are constants. The following V and T observations have been noted: <table border="1"><tr><td>V (m/min)</td><td>25</td><td>35</td></tr><tr><td>T (min)</td><td>90</td><td>20</td></tr></table> (i) Calculate n and C . (ii) Hence recommend the cutting speed for a desired tool life of 60 minutes.	V (m/min)	25	35	T (min)	90	20	05	4	3	6
V (m/min)	25	35									
T (min)	90	20									
4C	Using a schematic diagram, demonstrate the working of the powder bed fusion method in additive manufacturing, focusing on the laser-based system and the recoating mechanism.	05	2	3	5						
5A	Different alloy steel compositions are provided below. Analyze the given compositions, and based on the presence of the alloying elements, write the expected properties of each alloy steel. 1. C: 0.12%, Cr: 16%, Mo: 2%, N: 0.12% 2. C: 0.4%, Mn: 1.2%, Ni: 3%, Mo: 0.5% 3. C: 1.95%, Mn: 0.8%, Ni: 1.5%, Co: 0.5%	06	4	4	03						
5B	Define nanomaterials and elaborate on the top-down and bottom-up approaches used in their synthesis. Write any two applications of nanomaterials.	06	4	4	4						
5C	Apply your understanding of case hardening to explain its purpose and process. Analyze the following case hardening techniques by describing the elements added, their characterization, and applications: 1. Boronizing 2. Cyaniding 3. Nitriding.	08	3,4	4,5	2						
6A	Advanced aerospace structures require materials with high strength-to-weight ratio, excellent fatigue resistance, and the ability to operate reliably under severe thermal and mechanical loads. Explain why fibrous composites, particularly continuous fiber laminates, are preferred over isotropic bulk materials for such applications. In your answer, apply the functions of the matrix and reinforcement, discuss anisotropy, describe the load transfer mechanisms involved, and predict the most suitable type of reinforcement and matrix material for such applications, providing clear justification for your selections.	08	4	4	4						
6B	Apply your knowledge of material compositions to write the chemical composition of the following materials. Analyse their properties and suggest suitable engineering applications for each: 1. Cartridge Brass	06	3,4	3	3						



Bharatiya Vidya Bhavan's
SARDAR PATEL COLLEGE OF ENGINEERING

(Government Aided Autonomous Institute) Munshi Nagar,
Andheri (W) Mumbai - 4



~~END-SEMESTER November-2025/~~ RE - EXAM January 2026

	2. Admiralty Gun Metal 3. Dow Metal.				
6C	Explain the deep drawing and shearing operations in metal forming, and discuss the advantages of cold working.	06	4	3	7
7A	During an orthogonal machining operation on mild steel, the results obtained are $t_1 = 0.35$ mm, $t_2 = 0.70$ mm, $w = 2.5$ mm, $\alpha = 0^\circ$, $F_c = 950$ N, $F_t = 475$ N 1) Determine the coefficient of friction between the tool and the chip. 2) Calculate the shear stress of the work material.	06	2,3	4	6
7B	Identify the different types of powder density used in AM and describe how each is measured. Explain how these density values influence powder packing and melting behavior in SLM. Further analyze how layer thickness, laser power, scanning speed, and powder characteristics contribute to defect formation and affect the final quality of the AM product.	07	1,4	3	5
7C	A 350 mm-wide strip 40 mm thick is fed through a rolling mill with two powered rolls each of radius 250 mm. The work thickness is to be reduced to 37 mm in one pass at a roll speed of 50 rev/min. The work material has a flow curve defined by $K = 375$ MPa and $n = 0.17$, and the coefficient of friction between the rolls and the work is assumed to be 0.12. Determine if the friction is sufficient to permit the rolling operation to be accomplished. If so, calculate the roll force, torque, and horsepower.	07	2	3	7



Bharatiya Vidya Bhavan's

SARDAR PATEL COLLEGE OF ENGINEERING

(Government Aided Autonomous Institute)

Munshi Nagar, Andheri (W) Mumbai – 400058



END-SEM/Re/ EXAMINATIONS Nov 2025/Jan 2026

Program : BTech Mechanical engg *28/11/25* **Duration** : 3 hr

Course Code : PC-BTM304 **Maximum Points** : 100

Course Name : Strength of Materials.

Semester : III

Instruction : Refer below

1. Question No. 1 is compulsory
2. Solve any four out of remaining six.
3. Answers to each sub-questions are grouped together
4. Use of scientific calculator is allowed
5. Begin answer to each question on new page.
6. Keep some margin on left side of answer paper
- 7. Candidates should write the answer legibly**

Q. no.	Description	Pts	CO	BL
1	a) Define following terms: (i) Poission's Ratio, (ii) Modulus of rigidity, (iii) Bulk modulus, (iv) volumetric strain, (v) Ultimate tensile strength.. b) Draw the SFD and BMD of a simply supported beam of span 'L' for following cases: i) Point load 'W' at L/3 from left end, ii) UDL over the entire span. c) The ratio of maximum shear stress to average shear stress in beams of rectangular cross section is 1.5; prove it. d) Describe the Mohr's circle method for two-dimensional stress system.	5x 4	1,2 ,3	2,3
2	A 5 meter long simply supported beam carries a point load of 15 kN load at the right end and uniformly distributed load of 15 kN/m over the entire span. The two supports are 4 meter apart, the left hand support being at the left end. Calculate and draw the SFD, BMD and key points on it.	20	2	3
3	For state of stress as shown in fig. obtain the principal stresses and their planes ; also obtain the normal and shear stress on the plane $\Theta = 40^\circ$.	20	3	3

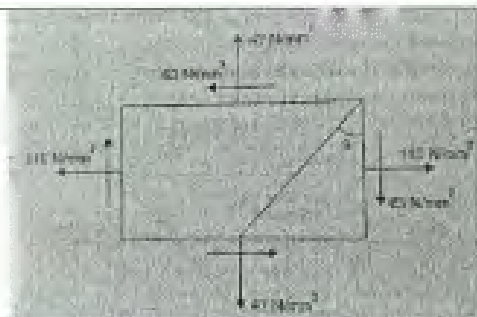

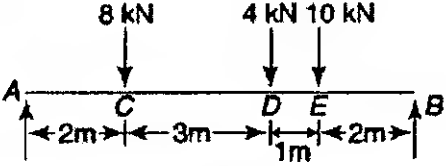
4	An I-section beam of 250 mm x 80 mm having flange thickness 6 mm and web thickness of 3 mm is subjected to shear force of 50 kN. Determine the maximum and minimum shear stress in the web. Calculate percentage of shear load carried by web.	20	2	3,4	
5	<p>a) Calculate the maximum bending stress induced for beam (as shown in figure) having cross section 90mm deep and 45 mm wide.</p> <p>b) What is section modulus? How does it influence bending stress?</p>		15	2	3,4
6	<p>a) A cylindrical shell, 1100 mm in diameter, thickness of metal 15 mm and 3.2 m long, is subjected to internal pressure of 1.8 MPa. Calculate the change in diameter, length and volume of shell under pressure. Use thin cylinder theory. $E = 210 \text{ GPa}$, Poisson's ratio = 0.27.</p> <p>b) A circular shaft transmits 30 kW at 400 rpm. It is supported in bearings 6 meters apart and at 2 meters from one bearing, it carries a rotor exerting a transverse load of 15 kN on the shaft. Determine a suitable diameter for the shaft taking into account both bending and torsional stresses if the maximum shear stress is not to exceed 40 MPa.</p>	10	2	3,4	
7	a) A simply supported beam has a span of 15 m and carries two point loads of 9 kN and 4 kN at 6 m and 10 m respectively from left end. Find the deflection under each load and the maximum deflection. $E = 200 \text{ GPa}$ and $I = 400 \times 10^6 \text{ mm}^4$.	20	4	3	



Bharatiya Vidya Bhavan's

SARDAR PATEL COLLEGE OF ENGINEERING

(Government Aided Autonomous Institute)

Munshi Nagar, Andheri (W) Mumbai - 400058



01

~~END SEM~~ / Re / EXAMINATIONS ~~Nov-2025~~ / Jan 2026

Program : BTech Mechanical engg *S. Y. D. T. Duration* .3 hr

Course Code : PC-BTM304

Maximum Points : 100

Course Name : Strength of Materials.

Semester : III

13/1/26

Instruction : Refer below

1. Question No. 1 is compulsory
2. Solve any four out of remaining six.
3. Answers to each sub-questions are grouped together
4. Use of scientific calculator is allowed
5. Begin answer to each question on new page.
6. Keep some margin on left side of answer paper
7. **Candidates should write the answer legibly**

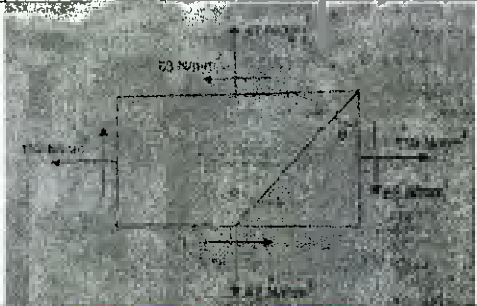
Q. no.	Description	Pts	CO	BL
1	<p>a) Define following terms: (i) Elastic limit, (ii) Modulus of rigidity, (iii) Bulk modulus, (iv) volumetric strain, (v) 0.2% offset proof stress.</p> <p>b) Draw the SFD and BMD of a cantilever beam of span 'L' for following cases: i) Point load 'W' at free end, ii) UDL over the entire span.</p> <p>c) Derive the expression for elongation of a taper bar, having diameter variation from 'd' to 'D' over a span of length 'L'; when load applied is 'P'.</p> <p>d) Prove that volumetric strain is given by the sum of linear strains measured along three orthogonal directions of a coordinate system.</p>	5x 4	1,2 ,3	2,3
2	<p>A 5 meter long simply supported beam carries a point load of 10 kN load at the right end and uniformly distributed load of 20 kN/m over the entire span. The two supports are 4 meter apart, the left hand support being at the left end. Calculate and draw the SFD, BMD and key points on it.</p>	20	2	3
3	<p>For state of stress as shown in fig. obtain the principal stresses and their planes ; also obtain the normal and shear stress on the plane $\Theta = 50^\circ$.</p> 	20	3	3
4	<p>a) An I-section beam of 300 mm x 100 mm having flange thickness 8 mm and web thickness of 4 mm is subjected to shear force of 150 kN. Determine the maximum and minimum shear stress in the web.</p>	10	1,2	3,4

	b) A bar of 12 mm diameter is acted upon an axial load of 20 kN. The change in diameter is measured as 0.003 mm. Determine; poisson's ratio, modulus of elasticity, bulk modulus if $G = 80$ GPa.	10		
5	a) Calculate the maximum bending stress induced for beam (as shown in figure) having cross section 70mm deep and 40 mm wide.	15	2	3,4
	b) Derive expression for hoop and longitudinal stresses in thin cylinder.	5		
6	a) A cylindrical shell, 1200 mm inside diameter, 20 mm thick and 2.4 m long, is subjected to internal pressure of 1.25 MPa. Calculate the hoop stress, longitudinal stress, maximum shear stress and change in diameter, length and volume of shell. $E=200$ GPa, Poisson's ratio = 0.3.	10	2	3,4
	b) A circular shaft transmits 60 kW at 120 rpm and is supported in bearings 6 meters apart . At 2.5 meters from one bearing, it carries a rotor exerting a transverse load of 12 kN on the shaft. Determine a suitable diameter for the shaft considering both bending and torsional stresses if the maximum shear stress is not to exceed 30 MPa.	10		
7	a) A simply supported beam has a span of 15 m and carries two point loads of 4 kN and 9 kN at 6 m and 10 m respectively from left end. Find the deflection under each load and the maximum deflection. $E = 200$ GPa and $I = 400 \times 10^6$ mm ⁴ .	15	2,4	2,3
	b) Show that in a rectangular c/s beam the maximum shear stress is 50% higher than mean shear stress.	5		

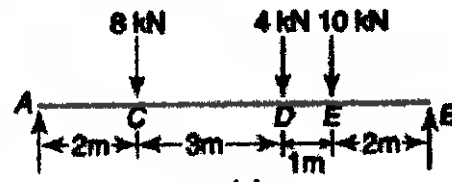



Bharatiya Vidya Bhavan's

SARDAR PATEL COLLEGE OF ENGINEERING

(Government Aided Autonomous Institute)

Munshi Nagar, Andheri (W) Mumbai - 400058

**End Semester Examination November 2025**Program: S.Y. Mechanical Engineering

Course Code: VE- BT001

Course Name: Health Safety and Sustainable Environment

Duration: 3 Hour

Maximum Points: 100

Semester: III

2/1/25

- Notes: 1. Solve any FIVE main questions
 2. Draw neat schematic diagrams wherever is necessary, highlight important points.
 3. Assume suitable data if necessary and mention it.

Q. No.	Questions	Pt	CO	BL	M
Q1 A	What is OSHA act 1970? (3 points) Enlist and explain the 3 motivating parameters for adopting occupational health and safety at any workplace?	10	2	1,2	1
Q1 B	Draw neat, labelled sketch for four-fold risk mitigation strategy? What is risk control system and its place/role in safety triangle? What is domino's theory in safety engineering?	10	1	2	2
Q2 A	Phosphoric acid and Ammonia mixed in reactor and produces fertilizer Diammonium phosphate, if ammonia gets consumed completely. In extreme cases, process led to manufacturing a complex chemical compound. Apply HAZOP study to this system explains all task stepwise in brief? Draw its worksheet?	10	2	2	3
Q2 B	What is PSC concept for fault tree construction? Basic Events G1, G2 & G3 (refers to failure of respective generator) will lead to system top level event 'TE' i.e. (unnecessary shutdown). Draw fault tree diagram for above case, then convert it into an equivalent AND & OR gate. Also calculate probability of occurrence of top-level events if each basic event's probability of occurrence is equal to 0.75.	10	2	1,3	4
Q3 A	Give any 6 commitments, to be fulfilled by the contracting parties in the Ramsar Convention? What are the benefits of joining the Ramsar Convention?	10	3	1	5
Q3 B	According to united states statistics division, what is definition of waste and its disposal? List down waste generation stages during lifecycle of any product. Give classification of waste according to different criteria's?	10	4	2	6
Q4 A	What is Sustainability in context of environment? Explain the following UN's sustainable goals; SDG6, SDG7, SDG 13	10	4	1	7
Q4 B	What is benefit of OHSAS 18001? What are the six sections of OHSAS 18001? List down all market driver of OHSAS 18001?	10	2	1	1

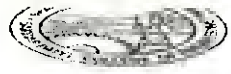
**End Semester Examination November 2025**

Q5 A	Draw Peterson accident causation model for Bhopal gas tragedy (Union Carbide India Limited)? list down the safety levers and use the tabular form explain their effect in the time domain for health and safety related issues?	10	1	2	2
Q5 B	Draw neat sketch Top-Down approach applied to a system using failure mode and effect analysis (FMEA) technique? Draw sketch of methodology and documentation table of FMEA?	10	1	1	3
Q6 A	Write a short note on cut set method? Using MICSUP (minimal cut set upward) algorithm find minimal cut-set for the following system? (Stepwise answer expected)	10	2	3	4
Q6 B	If a designated Wet Land shows the degradation in its ecology, suggest stepwise restoration of that wet land? What is Ramsar Convention? Give the criteria to designate wetland as per it's definition?	10	3	2	5
Q7 A	Explain 3R strategy (Hierarchy) to have the best possible waste management? What is impact of mismanagement in waste collection, storage on Health and socio-economic conditions?	10	4	1	
Q7 B	Identify specific air pollution control strategies for the following: Thermal power plant, Oil refineries, stone crushers?	10	4	1	7



Bharatiya Vidya Bhavan's
SARDAR PATEL COLLEGE OF ENGINEERING

(Government Aided Autonomous Institute)
Munshi Nagar, Andheri (W) Mumbai – 400058



END SEMESTER November 2025 / ~~RE-EXAM~~ January 2026

S.Y.
Program: B.Tech. Mechanical *Sem III*
Course Code: PC-BTM305
Course Name: Computer Aided Mechanical Drawing

17/11/25
Duration: 3 hrs.
Maximum Points: 100.
Semester: III

Important Notes:

1. Question 1 is compulsory.
2. Attempt any three out of remaining five questions.
3. Create a new folder and rename it to <Reg. No._CAMD_ENDSEM>
4. Create separate .dwg file for each question and save in the above created folder only. File name should be <Q1_Reg. no._Endsem>.
5. Answers to free hand sketches should be drawn on given A4 answer sheet and submit is back.
6. Students to carry only Admit Card, Pen, Pencil, eraser and sharpener in Exam Hall. Use of scale and any geometric instrument is prohibited in Exam Hall.
7. At the end of exam, your folder with autocad and pdf files will be uploaded by the authorized person. Before leaving the exam seat, student have to confirm that his/her folder is uploaded by the authorized person.
8. Assume suitable data wherever only if necessary.
9. **Save your Work** in AutoCad Regularly.

Q. No.		Points	MO/CO	BL
Q.1	Given in the figure is the details of Knuckle Joint. Draw the following assembly views:		03/--	03
	a) Sectional Front View	07	01	
	b) Side View	06	03	
	c) Create a Bill of Material and plot a pdf file of the assembly with given CAMD Exam layout.	04	04	
	d) Draw Free Hand Sketches of the following:		02/	01
	i. BA Thread.	04	02	
	ii. Buttress Thread	04		



Bharatiya Vidya Bhavan's
SARDAR PATEL COLLEGE OF ENGINEERING

(Government Aided Autonomous Institute)
Munshi Nagar, Andheri (W) Mumbai - 400058



END SEMESTER November 2025 / ~~RE-EXAM~~ January 2026

Q.2	A vertical cylinder, diameter 70 mm and axis 110 mm is resting on its base on the H.P. A horizontal square prism, base 30 mm, sides equally inclined to V.P. Axis of horizontal prism is parallel to both the V.P. and H.P. and penetrates the cylinder. The axis of the solids intersects each other at right angle and prism axis is 55 mm above the cylinder base.		01/-	03
	a) Create 3d models of the cylinder and prism.	06	01	
	b) Create a copy of 3d models of the cone- prism and assemble them as described in problem statement.	04	03	
	c) Plot 2d projections of the assembly in F.V., T.V., and S.V. showing curves of intersections in the given CAMD Exam layout.	07	04	
	d) Draw Free Hand Sketches of the following: 1. Hexagonal Nut. 2. Chamfered Washer	04 04	02/ 02	01
Q.3	Given in the figure is the Details of Protected Flange Coupling. Complete the following tasks.		04/-	03
	a) Create the Part drawing in 3d space.	07	01	
	b) Make one copy of each part and assemble the parts at their functional positions and plot following views in 2d layout. i) Sectional Front View. ii) Side View	03 05	03 03	
	c) Create a Bill of Material and plot a pdf file of the assembly with given CAMD Exam layout.	05	04	
	d) Draw Free Hand Sketches of the following: 1. Gib Headed Key	05	04/ 02	01



Bharatiya Vidya Bhavan's
SARDAR PATEL COLLEGE OF ENGINEERING

(Government Aided Autonomous Institute)
Munshi Nagar, Andheri (W) Mumbai - 400058



END SEMESTER November 2025 / ~~RE~~ - EXAM January 2026

Q.4	Given in the figure is the drawing of V- Belt Pulley. Complete the following tasks.		05/--	03
	a) Create the 3d model of V-Belt.	10	01	
	b) Plot Side View and	04	03	
	c) Plot Sectional Front View of Assembly in 2d layout with CAMD Exam Layout and create PDF.	06	04	
	d) Calculate the limits for $\text{Ø}35 \text{ H7, g6}$	05	02/ 02	01
Q.5	Given in the figure is the Expansion Valve Assembly.		06/--	03
	a) Create 3d model of following parts			
	I. Gland	06	03	
	II. Gland Bush	04	03	
	b) From 3d, plot the following views of Gland in 2d layout.	08	04	
	I. Front View			
	II. Side View			
	c) From 3d, plot the following views of Gland Bush in 2d layout.	07	04	
	I. Front View			
	II. Side View			



Bharatiya Vidya Bhavan's
SARDAR PATEL COLLEGE OF ENGINEERING

(Government Aided Autonomous Institute)
 Munshi Nagar, Andheri (W) Mumbai - 400058



END SEMESTER November 2025 / RE-EXAM January 2026

Q.6	Given in the figure is the Drill Jig Assembly.		07/--	03
	a) Create 3d model of following parts			
	I. Jig Plate	05	03	
	II. Latch Washer	05	03	
	b) From 3d, plot the following views of Jig plate in 2d layout.	08	04	
	I. Sectional Front View			
	II. Top View			
	c) From 3d, plot the following views of Latch Washer in 2d layout.	07	04	
	I. Sectional Front View			
	II. Top View			

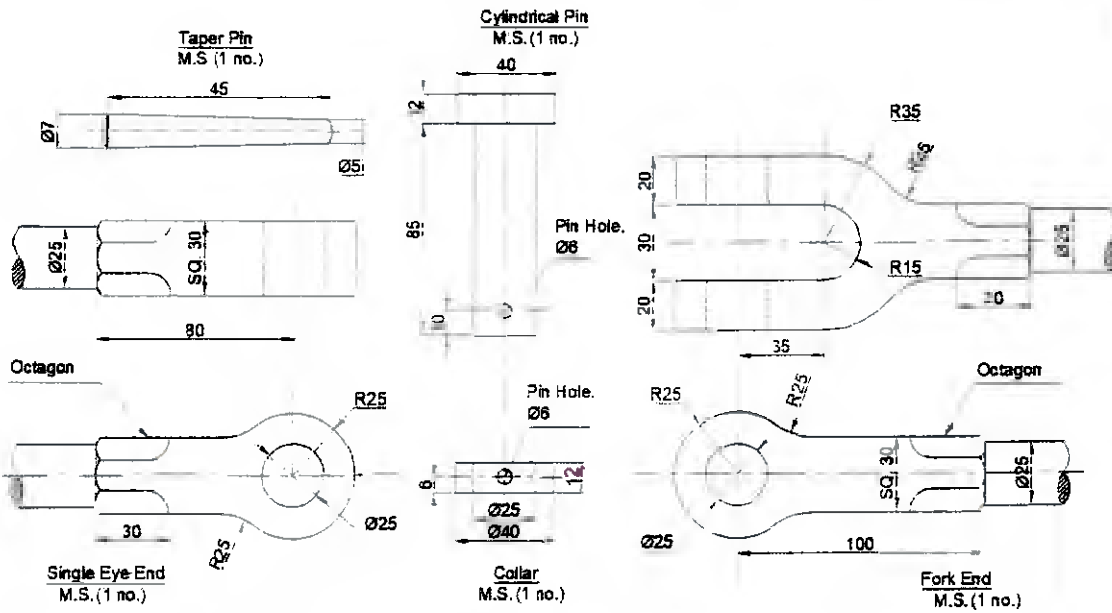

Q.1. Knuckle Joint



END SEMESTER November 2025 / ~~RE-EXAM~~ January 2026

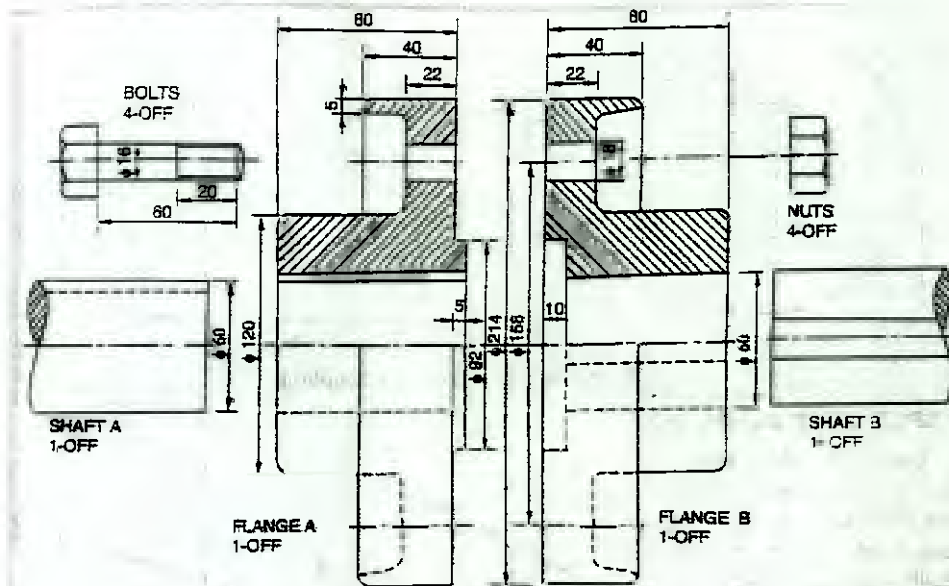

Q.3. Protected Type Flange Coupling

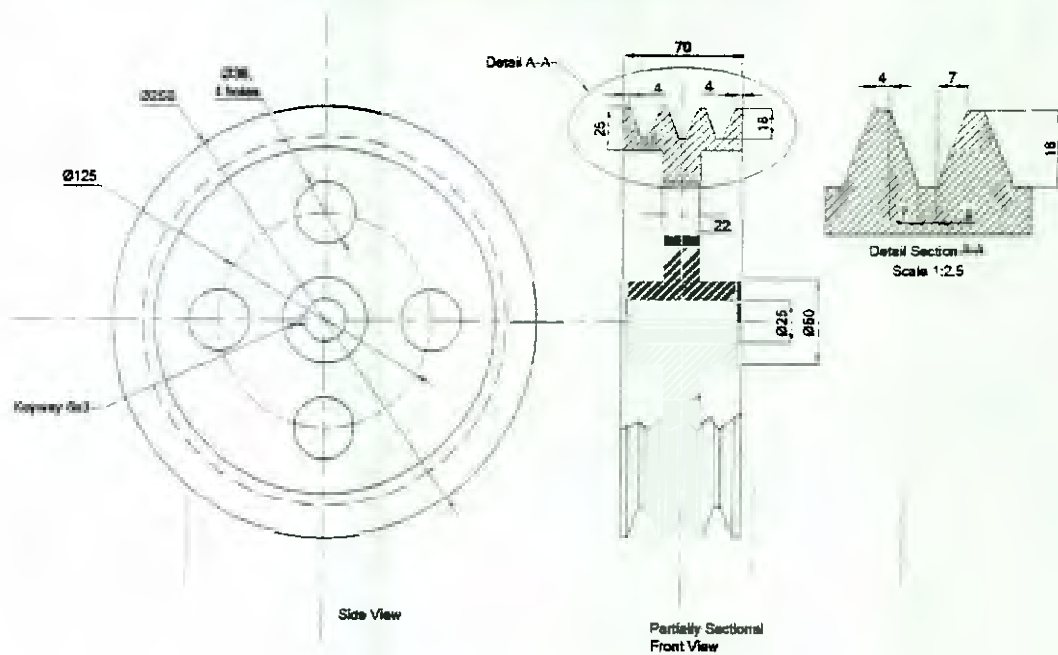

Q.4. V-Belt Pulley



END SEMESTER November 2025 / RE - EXAM January 2026

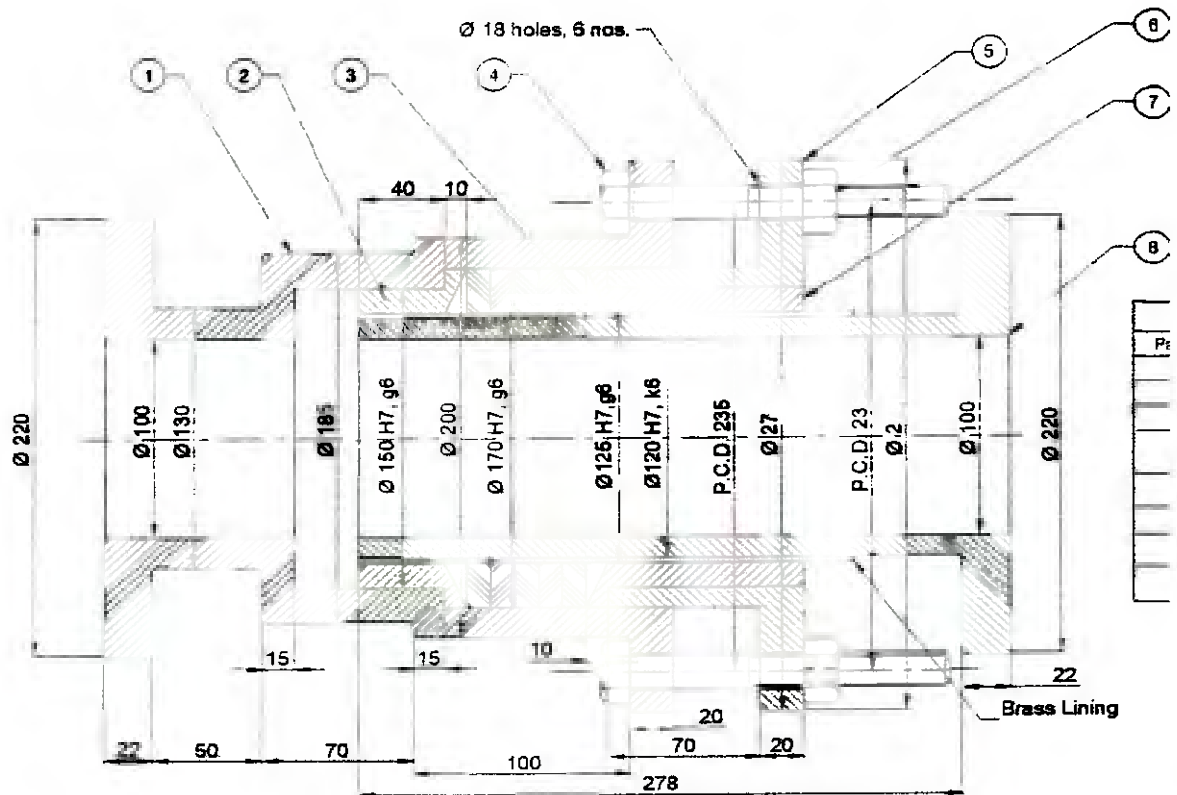

Q.5. Expansion Joint



Bharatiya Vidya Bhavan's
SARDAR PATEL COLLEGE OF ENGINEERING

(Government Aided Autonomous Institute)
 Munshi Nagar, Andheri (W) Mumbai - 400058



END SEMESTER November 2025 / ~~RE~~ EXAM January 2026

Limits, Tolerance Tables

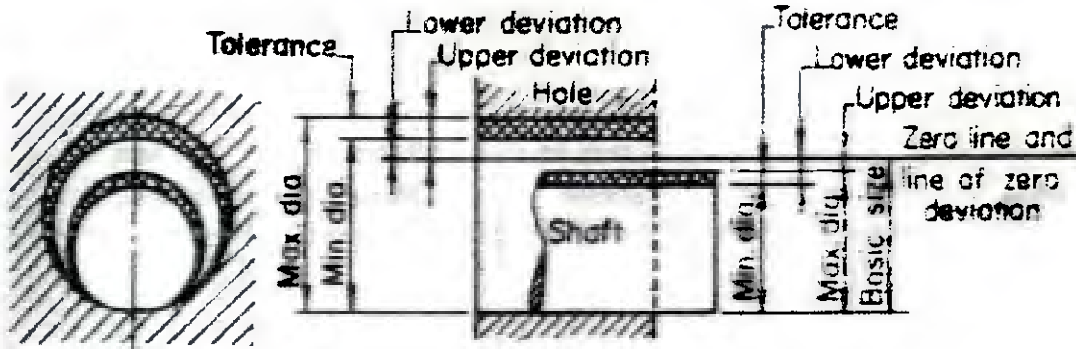

Table 1 Recommended diameter steps upto 500 mm (13 steps)

Over	-	3	6	10	18	30	50	80	120	180	250	315	400
Upto	3	6	10	18	30	50	80	120	180	250	315	400	500

Table 2 Equations to calculate fundamental deviation of shaft size up to 500 mm (D = Geometrical mean dia. in mm)

Symbol	Fundamental deviation in microns	Symbol	Fundamental deviation in microns
d	$-16D^{0.44}$	js	$\pm (IT/2)$
e	$-11D^{0.41}$	k4 to k7	$+0.63D^{1/2}$
f	$-5.5D^{0.41}$	m	$+(IT7 - IT6)$
g	$-2.5D^{0.34}$	n	$+5D^{0.34}$
h	0	p	$+(IT7 + 0 \text{ to } 5)$

Table 3 Fundamental Tolerance for IT grades in terms of i.

IT Grade	IT5	IT6	IT7	IT8	IT9	IT10	IT11	IT12	IT13	IT14	IT15	IT16
Tolerance in Microns	7i	10i	16i	25i	40i	64i	100i	160i	250i	400i	640i	1000i



Bharatiya Vidya Bhavan's
SARDAR PATEL COLLEGE OF ENGINEERING

(Government Aided Autonomous Institute)
Munshi Nagar, Andheri (W) Mumbai – 400058



~~END SEMESTER November 2025~~ / RE - EXAM January 2026

8/1/26

Program: B.Tech. Mechanical *S-4.* *Sem III* *III*

Duration: 3 hrs.

Course Code: PC-BTM305

Maximum Points: 100.

Course Name: Computer Aided Mechanical Drawing

Semester: III

Important Notes:

1. Question 1 is compulsory.
2. Attempt any three out of remaining five questions.
3. Create a new folder and rename it to <Reg. No. _CAMD_ENDSEM>
4. Create separate .dwg file for each question and save in the above created folder only. File name should be <Q1_Reg. no. _Endsem>.
5. Answers to free hand sketches should be drawn on given A4 answer sheet and submit is back.
6. Students to carry only Admit Card, Pen, Pencil, eraser and sharpener in Exam Hall. Use of scale and any geometric instrument is prohibited in Exam Hall.
7. At the end of exam, your folder with autocad and pdf files will be uploaded by the authorized person. Before leaving the exam seat, student have to confirm that his/her folder is uploaded by the authorized person.
8. Assume suitable data wherever only if necessary.
9. **Save your Work in AutoCad Regularly.**

Q. No.		Points	MO/CO	BL
Q.1	Given in the figure is the details of Spigot and Socket Joint. Draw the following assembly views:		03/--	03
	a) Sectional Front View	07	01	
	b) Side View	06	03	
	c) Create a Bill of Material and plot a pdf file of the assembly with given CAMD Exam layout.	04	04	
	d) Draw Free Hand Sketches of the following:		02/	01
	i. Metric Thread.	04	02	
	ii. Buttress Thread	04		



Bharatiya Vidya Bhavan's
SARDAR PATEL COLLEGE OF ENGINEERING

(Government Aided Autonomous Institute)
Munshi Nagar, Andheri (W) Mumbai – 400058



END SEMESTER November 2025 / RE - EXAM January 2026

Q.2	A vertical cone, diameter 70 mm and axis 110 mm is resting on its base on the H.P. A horizontal square prism, base 30 mm, sides equally inclined to V.P. Axis of horizontal prism is parallel to both the V.P. and H.P. and penetrates the cone. The axis of the solids intersects each other at right angle and prism axis is 30 mm above the cone base.		01/--	03
	a) Create 3d models of the cone and prism.	06	01	
	b) Create a copy of 3d models of the cone- prism and assemble them as described in problem statement.	04	03	
	c) Plot 2d projections of the assembly in F.V., T.V., and S.V. showing curves of intersections in the given CAMD Exam layout.	07	04	
	d) Draw Free Hand Sketches of the following: 1. Collar Neck Stud. 2. Hook Headed-Bolt	04 04	02/ 02	01
Q.3	Given in the figure is the Details of Standard Flange Coupling. Complete the following tasks.		04/--	03
	a) Create the Part drawing in 3d space.	07	01	
	b) Make one copy of each part and assemble the parts at their functional positions and plot following views in 2d layout. i) Sectional Front View. ii) Side View	03 05	03 03	
	c) Create a Bill of Material and plot a pdf file of the assembly with given CAMD Exam layout.	05	04	
	d) Draw Free Hand Sketches of the following: 1. Taper Rectangular Key	05	04/ 02	01



Bharatiya Vidya Bhavan's
SARDAR PATEL COLLEGE OF ENGINEERING
(Government Aided Autonomous Institute)
Munshi Nagar, Andheri (W) Mumbai – 400058



~~END SEMESTER November 2025~~ / RE - EXAM January 2026

Q.4	Given in the figure is the drawing of V- Belt Pulley. Complete the following tasks.		05/--	03
	a) Create the 3d model of V-Belt.	10	01	
	b) Plot Side View and	04	03	
	c) Plot Sectional Front View of Assembly in 2d layout with CAMD Exam Layout and create PDF.	06	04	
	d) Calculate the limits for $\varnothing 25$ H8, f8	05	02/ 02	01
Q.5	Given in the figure is the Expansion Valve Assembly.		06/--	03
	a) Create 3d model of following parts			
	I. Body	06	03	
	II. Gland	04	03	
	b) From 3d, plot the following views of Body in 2d layout.	08	04	
	I. Sectional Front View			
	II. Side View			
	c) From 3d, plot the following views of Gland in 2d layout.	07	04	
	I. Sectional Front View			
	II. Side View			



Bharatiya Vidya Bhavan's
SARDAR PATEL COLLEGE OF ENGINEERING

(Government Aided Autonomous Institute)
Munshi Nagar, Andheri (W) Mumbai - 400058



END SEMESTER ~~November 2025~~ / RE - EXAM January 2026

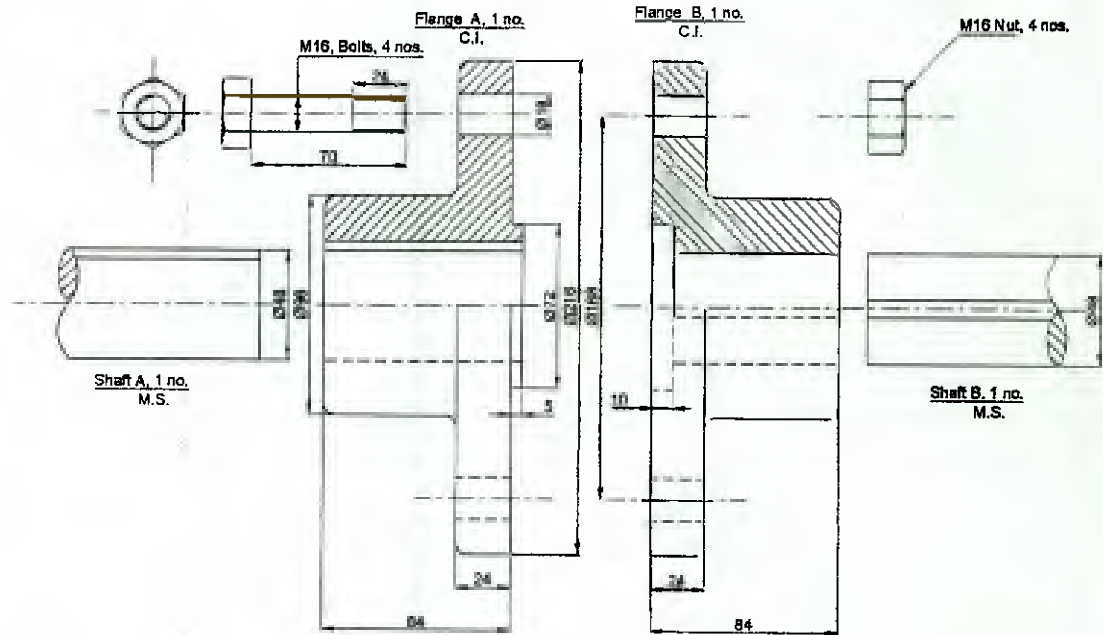

Q.3. Standard Flange Coupling

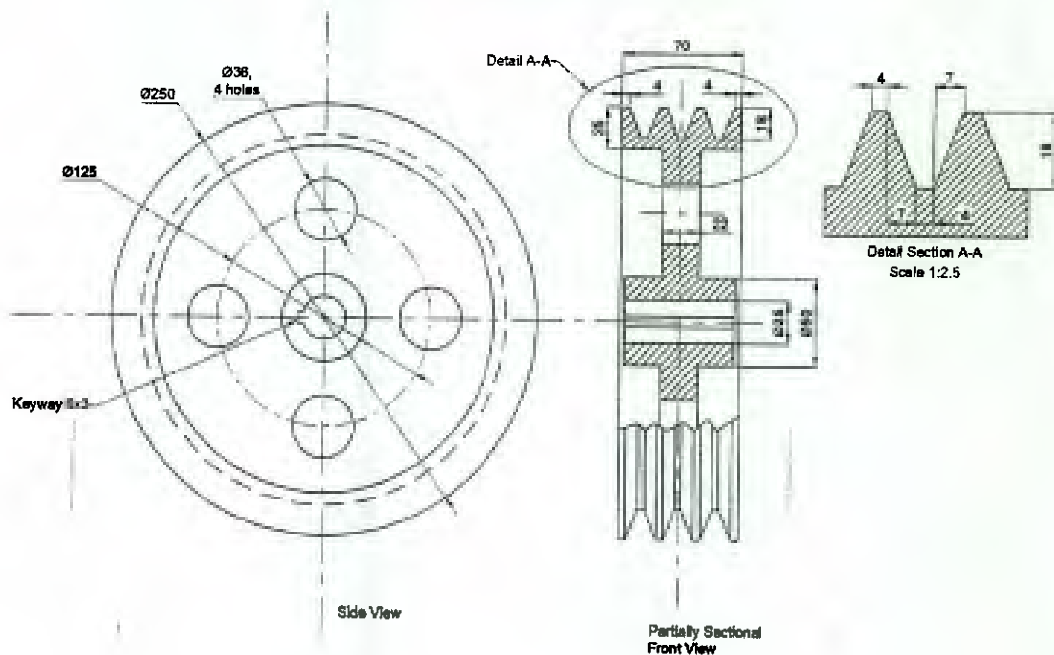

Q.4. V-Belt Pulley



Bharatiya Vidya Bhavan's
SARDAR PATEL COLLEGE OF ENGINEERING

(Government Aided Autonomous Institute)
Munshi Nagar, Andheri (W) Mumbai – 400058



END SEMESTER ~~November 2025~~ / RE - EXAM January 2026

Limits, Tolerance Tables

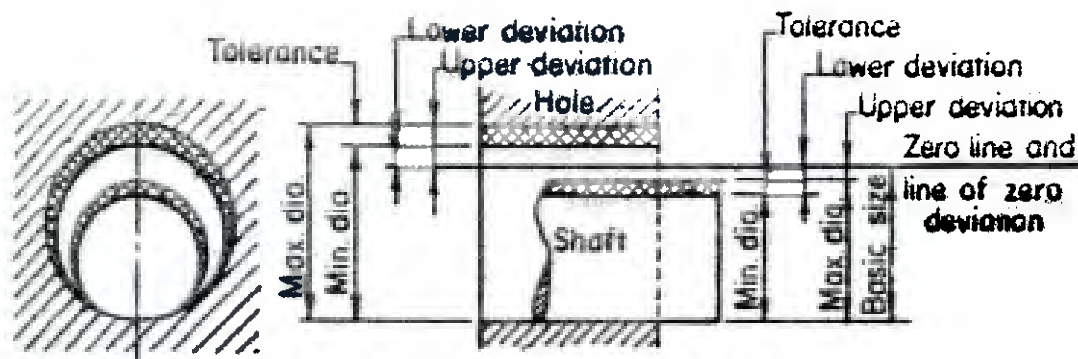

Table 1 Recommended diameter steps upto 500 mm (13 steps)

Over	-	3	6	10	18	30	50	80	120	180	250	315	400
Upto	3	6	10	18	30	50	80	120	180	250	315	400	500

Table 2 Equations to calculate fundamental deviation of shaft size up to 500 mm (D = Geometrical mean dia. in mm)

Symbol	Fundamental deviation in microns	Symbol	Fundamental deviation in microns
d	$-16D^{0.44}$	js	$\pm (IT/2)$
e	$-11D^{0.41}$	k4 to k7	$+0.63D^{1/2}$
f	$-5.5D^{0.41}$	m	$+(IT7 - IT6)$
g	$-2.5D^{0.34}$	n	$+5D^{0.34}$
h	0	p	$+(IT7 + 0 \text{ to } 5)$

Table 3 Fundamental Tolerance for IT grades in terms of i.

IT Grade	IT5	IT6	IT7	IT8	IT9	IT10	IT11	IT12	IT13	IT14	IT15	IT16
Tolerance in Microns	7i	10i	16i	25i	40i	64i	100i	160i	250i	400i	640i	1000i

**END SEMESTER ~~November 2025~~ / RE - EXAM January 2026**

6/11/26

Program: **Mechanical** *S.Y. B.Tech (M) Sem III* Duration: 3 hoursCourse Code: **ES-BTM301**

Maximum Points: 100

Course Name: **Linear Algebra & vector calculus**Semester: **III**

Notes: 1) Attempt any 5 out of 7 questions

2) Use of non-programmable calculator is allowed.

Q.No.	Questions	Points	CO	BL	Mod No.
1a)	Find a unit vector normal to the surface $xy^3z^2 = 4$ at point $(-1, -1, 2)$	06	4	1,2	3
1b)	If $A = \begin{bmatrix} 3 & -3 & 4 \\ 2 & -3 & 4 \\ 0 & -1 & 1 \end{bmatrix}$, Find two non singular matrices P and Q such that $PAQ = I$. Hence find A^{-1} .	06	1	1,2,3	1
1c)	Obtain the Fourier Series for $f(x) = \sin x \quad -\pi \leq x \leq \pi$	08	2	2,3	5
2a)	Test for consistency and solve: $5x + 3y + 7z = 4, 3x + 26y + 2z = 9, 7x + 2y + 10z = 5$	06	1	1,3	1
2b)	Find the bilinear transformation which maps $z = 2, 1, 0$ onto $w = 1, 0, i$	06	3	2	7
2c)	By using the sine series for $f(x) = 1$ in $0 < x < \pi$. Hence using parseval identity show that $\frac{\pi^2}{8} = 1 + \frac{1}{3^2} + \frac{1}{5^2} + \frac{1}{7^2} + \dots$	08	2	1,2,3	6



Bhambhaniya Vidya Bhawan's
SARDAR PATEL COLLEGE OF ENGINEERING

(Government Aided Autonomous Institute)
Munshi Nagar, Andheri (W) Mumbai - 400058



END SEMESTER November 2025 / RE - EXAM January 2026

3a)	Verify Divergence Theorem for $\vec{F} = 4x\hat{i} - 2y^2\hat{j} + z^2\hat{k}$ taken over the bounded by the cylinder $x^2 + y^2 = 4, z = 0, z = 3$	10	4	1,3	4
3b)	Use Cayley-Hamilton theorem to find $2A^5 - 3A^4 + A^2 - 4I$ where $A = \begin{bmatrix} 3 & 1 \\ -1 & 2 \end{bmatrix}$	10	1	2,3	2
4a)	Find all the eigen values and eigenvectors of the matrix $A = \begin{bmatrix} -2 & 2 & -3 \\ 2 & 1 & -6 \\ -1 & -2 & 0 \end{bmatrix}$	10	1	1,2,3	2
4b)	Verify Stoke's theorem for the vector field $\vec{F} = (x^2 - y^2)\hat{i} + 2xy\hat{j}$ over the box bounded by planes $x = 0, x = a, y = b, z = C$ if the face $z = 0$ is cut.	10	4	1,2	4
5a)	Prove that $\nabla \times \left(\frac{\vec{a} \times \vec{r}}{r^n} \right) = \frac{(2-n)\vec{a}}{r^n} + \frac{n(\vec{a} \cdot \vec{r})\vec{r}}{r^{n+2}}$	06	4	1,2,3	4
5b)	Obtain the Fourier Series for $f(x) = x \sin x$ in $(0, 2\pi)$	06	2	1,3	
5c)	Find the image of the semi infinite, strip $x > 0, 0 < y < 2$ under the transformation $w = iz + 1$.	08	3	2,3	7
6a)	If $A = \frac{1}{3} \begin{pmatrix} 1 & 2 & a \\ 2 & 1 & b \\ 2 & -2 & c \end{pmatrix}$ is orthogonal find a, b and c	06	1	1,3	1
6b)	Find the Fourier Series for function $f(x)$ defined by $f(x) = \begin{cases} \pi x & 0 \leq x \leq 1 \\ \pi(2-x) & 1 \leq x \leq 2 \end{cases}$	06	2	1,2,3	6



SARDAR PATEL COLLEGE OF ENGINEERING

(Government Aided Autonomous Institute)
Munshi Nagar, Andheri (W) Mumbai - 400058



END SEMESTER November 2025 / RE - EXAM January 2026

6c)	If $\vec{F} = x^2 \hat{i} + (x - y) \hat{j} + (y + z) \hat{k}$ displace a particle from A (1, 0, 1) to B (2, 1, 2) along St.Line A B. Find the work done.	08	4	2,3	3
7a)	For the values of λ and μ , the following system of equations $2x + 3y + 5z = 9, 7x + 3y - 2z = 8, 2x + 3y + \lambda z = \mu$ will have (i) unique solution, (ii) no solution	06	1	1,2	1
7b)	Verify Green's theorem in the plane for $\oint_C (3x^2 - 8y^2) dx + (4y - 6xy) dy$ where C is the boundary of region defined by $y = \sqrt{x}$ & $y = x^2$.	06	4	1,2,3	4
7c)	If $u = \frac{\sin 2x}{\cosh 2y + \cos 2x}$, find $f(z)$ using Milne Thomson method	08	3	2,3	7